

SES

Seametrics

SES STAINLESS SINGLE-JET METER INSTRUCTIONS

STAINLESS SINGLE-JET METER INSTRUCTIONS

18' (6 m) Sensor Cable

Thread-in Sensor, Field Replaceable,
6-24 Vdc Pulse

316 Stainless Steel Body

Removeable 316 SS Cover

Female NPT Thread

Hex Screws

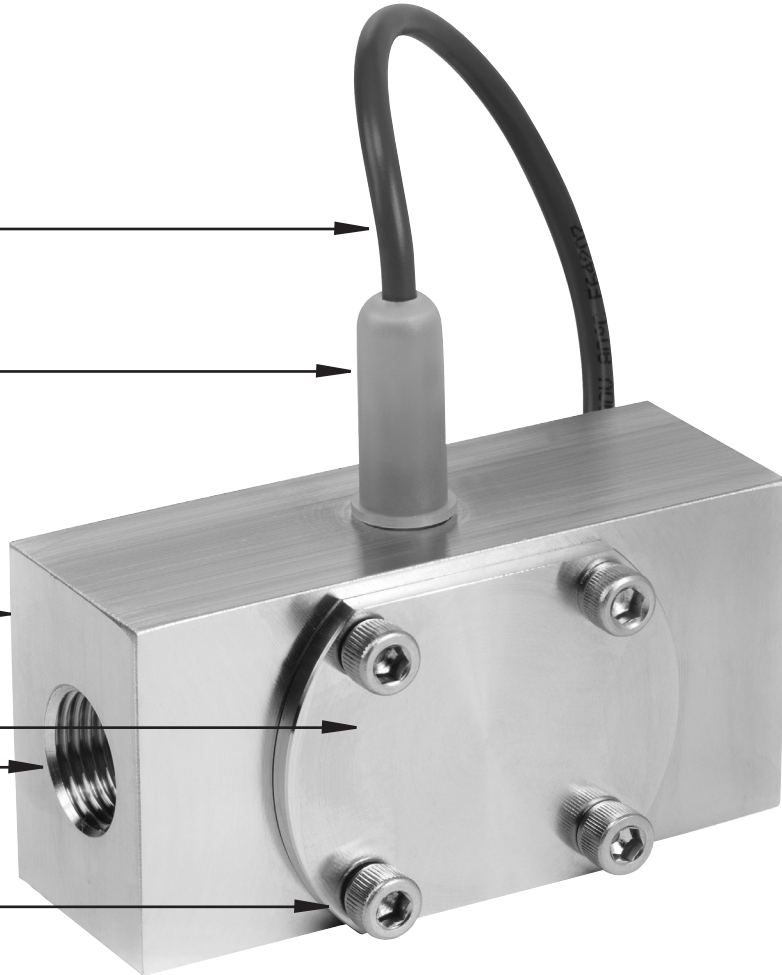

(Internal)
Jewel Bearings
Kynar/Carbide Rotor Assembly
Teflon-Coated Viton® O-Ring

ISO 9001:2008
CERTIFIED COMPANY

GENERAL INFORMATION

The SES stainless single-jet meter provides accurate, wide range flow metering in an extremely rugged stainless steel package. Single-jet simplicity combined with high quality jewel bearings results in long life and relatively high tolerance for problem fluids. Typical applications are chemical batching, proportional chemical injection, fertilizer injection, proportioning of spray chemicals, and general flow rate monitoring.

and is compatible with most Seametrics indicators and transmitters, as well as most controls and PLC's that accept DC inputs. The standard rotor is PVDF (Kynar) and the shaft is a nickel-bonded tungsten carbide. The optional ceramic shaft increases resistance to some concentrated chemicals. The standard O-ring is Teflon-coated Viton.

The sensor is easily replaced from outside the meter

SPECIFICATIONS*

Connection Ports	1/2", 3/4", and 1" female NPT thread
Sensor Cable	18 feet (6 m) standard (Max. cable run 2000 ft.)
Materials	
Body	316 stainless steel
Rotor	PVDF (Kynar)
Shaft	Nickel-bonded tungsten carbide
Bearings	Ruby ring and ball
O-Ring	Teflon-coated Viton
Cover	316 stainless steel
Maximum Temperature	200° F (93° C)
Maximum Pressure	500 psi (35 bar)
Accuracy	+/- 1% of full scale
Power	5-24 Vdc, 2 mA min
Outputs	Current sinking pulse, 6 - 24 Vdc

*Specifications subject to change • Please consult our website for current data (www.seametrics.com).

FLOW RANGE

Model	K-Factor (pulses/gal)	Flow
-050	535	0.1-10 GPM (.38-38 LPM)
-075	390	0.2-15 GPM (.75-57 LPM)
-100	220	0.5-25 GPM (1.9-95 LPM)

GPM = Gallons/Minute
LPM = Liters/Minute

DIMENSIONS

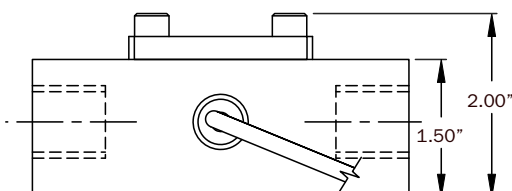
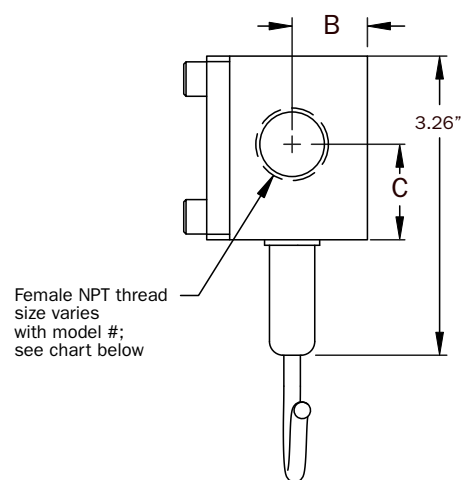
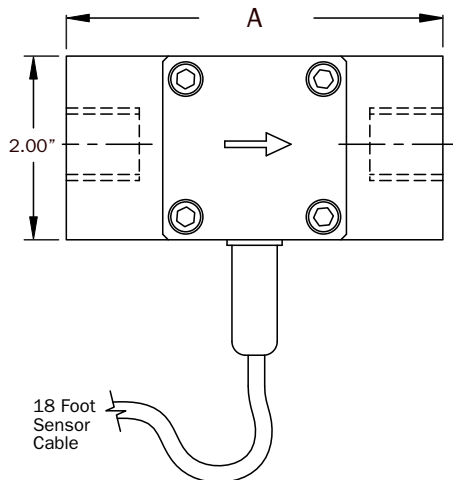

Model #	NPT Thread Size	A	B	C
-050	1/2 inch	4.10	.82	1.04
-075	3/4 inch	4.10	.82	1.04
-100	1 inch	5.00	.75	1.00

INSTALLATION

Piping Requirements. Standard fittings are female NPT. Straight pipe of at least five diameters upstream of the meter is recommended. Vertical, horizontal, or inverted (cover down) installations are all acceptable.



Warning: This meter has low-friction bearings. **DO NOT, AT ANY TIME,** test operation of the meter with compressed air! Doing so will subject it to rotational speeds many times those for which it was designed, and will certainly damage the rotor, shaft, and/or bearings.

K-Factor. The meter is factory calibrated. The K-factor is found on the label on the meter body and must be input into the control/display for accurate reading.



CONNECTIONS

Connecting to Non-Seametrics Control Devices.

It is often desirable to connect an SES flow sensor to a PLC or industrial computer board, and the sensors are well suited for this. Typically it can be connected directly, or with a single resistor added. The pickup sensors are current sinking (NPN) GMR devices that require 5-24 Volts DC and 2 mA current. They can connect directly to a PLC or computer board (see **Fig. 1**) if:

1. The sensor power supply on the PLC is 5 - 24 Vdc (24 Vdc is typical).
2. The sensor power supply can provide at least 2 mA (100mA is typical).
3. The sensor input on the PLC can accept a current sinking device.
4. The PLC frequency response > flow meter output frequency.

If the PLC input only accepts current sourcing devices, a pull-

up resistor must be added (see **Fig. 2**). Typically, on a 24 Vdc input a 2.2 K Ohm resistor will be effective.

Since the three-wire pickup sensors are solid state, they do

Figure 2

Input Designed for Current Sourcing (PNP) Devices

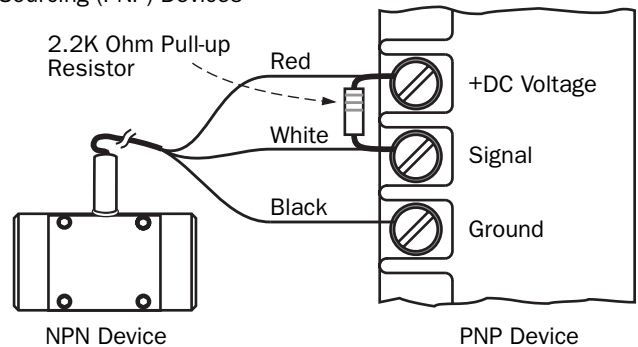
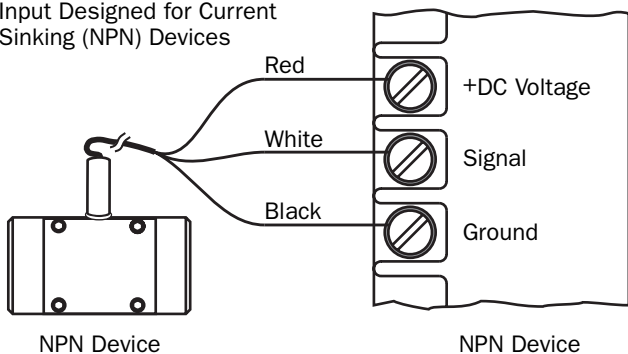

Figure 1

Input Designed for Current Sinking (NPN) Devices



not exhibit switch bounce and can be used at relatively high frequencies.

If the PLC is equipped with a 4-20 mA analog input module, it is necessary to order the SES flow sensor with some form of 4-20 mA transmitter. Two options are the A055 blind transmitter and the FT420 indicating transmitter. Follow the connection diagrams for these products to connect to the analog input.

MAINTENANCE and REPAIR

Rotor Replacement. There is only one moving part to this meter. The bearings are made of ruby, which rarely wears out or needs replacement unless they have been physically damaged by severe shock. The shaft is integrally molded into the rotor, and shaft and rotor are replaced as one part. (You may wish to replace the bearings, using the bearing removal tool, while the meter is disassembled for rotor replacement). To replace the rotor, disconnect the meter and remove the four screws that hold the cover in place. Lift the cover and bearing plate and remove the rotor (see parts diagram below).

When putting in the new rotor, be sure that the ends of the shaft are in both bearings before tightening the cover. The rotor can be easily dropped into the bottom bearing. Starting the shaft into the upper bearing requires a bit of care. It is easier if the rotor is spinning, which can be done by lightly blowing into a port. When the upper bearing plate drops into place, hold it down and check for free spinning (by blowing lightly) before replacing the cover. Check that the O-ring is in its seat on the bearing plate before replacing the cover. Replace the cover, insert the four cap screws and tighten.

Sensor Replacement. The sensor ordinarily does not need

replacement unless it is electrically damaged. If replacement is necessary, unthread the sensor by hand. Thread the replacement sensor in and tighten by hand.



Reconnect the sensor according to the diagram below.

SENSOR CONNECTIONS

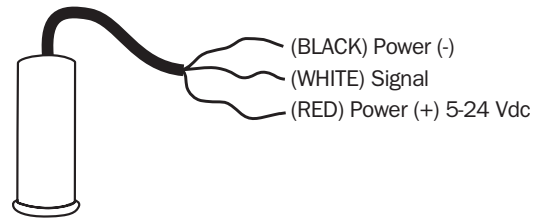

SES PARTS LISTING

1	Body, Stainless Steel	
	-050 (1/2 inch)	100683
	-075 (3/4 inch)	100684
	-100 (1 inch)	100685
2	Bearing Assembly (2 required)	100230
	Bearing Removal Tool (not shown)	100372
*3	Rotor Assembly, Kynar/Carbide	100034
*4	O-Ring, Teflon-Coated Viton	100973
5	Cover (Stainless Steel) SES -050/-075	100082
5	Cover (Stainless Steel) SES -100	100800
6	Hex Screw (4 required)	100693
7	Sensor	100419

*Alternate materials available for compatibility with a variety of chemicals.

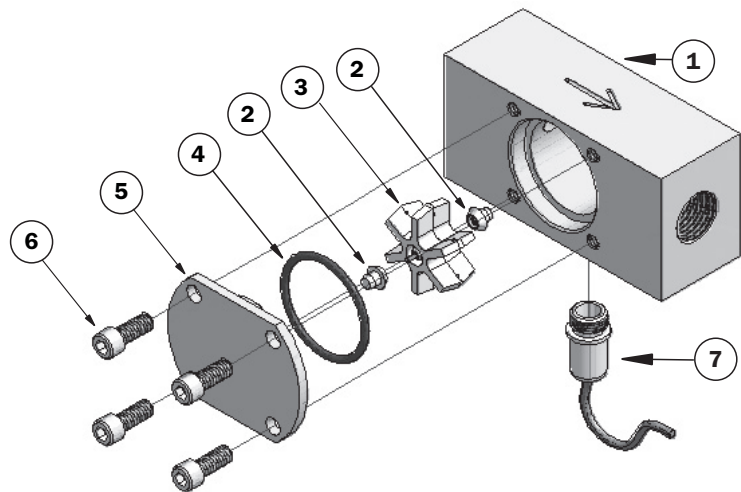

Seametrics

Seametrics Incorporated • 19026 72nd Avenue South • Kent, Washington 98032 • USA
(P) 253.872.0284 • (F) 253.872.0285 • 1.800.975.8153 • www.seametrics.com

LT-65200186-082014
8/20/2014