

Seametrics

iMAG 4700

Municipal/Industrial Magmeter
Instructions



General Information

General Information Page 3
 Features Page 3
 Specifications Page 4
 Dimensions Page 5
 Flow Rate Page 6
 Accuracy Page 6

Installation

Positioning the Meter Page 7
 Equalization and Grounding (Metal and Plastic Pipe) Page 7
 Straight Pipe Recommendations Page 8
 Full Pipe Recommendations Page 9

Connections

General Cable Information Page 10
 Cable Gland Opening and Sealing Page 11
 Cable Installation Page 11
 Wiring Diagrams Page 12
 Cable Wiring Table Page 14

Configuration

Sourcing Mode Output Application Page 15
 Sinking Mode Output Application Page 15
 Analog (4-20mA Current Loop) Output Application Page 15
 Cable Shield Page 16
 Pulse Output Page 16
 Analog (4-20mA) Output Page 16
 HART Output Page 16
 Modbus Output Page 16
 Digital Output Page 16

Operation

Changing Flow Meter Settings - Home Screen and General Navigation Page 17
 Changing Flow Meter Settings - Making Selections Page 17
 Changing Flow Meter Settings - Standard Menu Options Page 18
 Changing Flow Meter Settings - Special Submenu Page 18
 Battery Powered Units Page 19

Troubleshooting

Problem Back
 Probable Cause Back
 Things to Try Back

Note: These instructions cover the iMAG 4700. For details on the iMAG 4700p or 4700r, see the *iMAG 4700p* or *iMAG 4700r Municipal/Industrial Magmeter Instructions*.

The **iMAG-Series** is the most economical flanged electromagnetic flowmeter on the market. With electrodes designed to discourage fouling, it is available in 4" to 12" pipe in municipal or industrial water, waste and reclaimed water, pump stations, and packaged plant applications. (For 3" version, see iMAG 4600-300.) Minimal straight pipe requirements allow iMAG-Series meters to be used in piping configurations where there is little space between the meter and an elbow.

iMAG-Series meters are NSF-61 approved and are rated IP68 for applications where the meter may be operated under water to a depth of at least 10 feet (3 meters) continuously.

Rate and total units and pulse scaling can be set via the front panel touch key pad by the user. Bidirectional flow is standard with forward, reverse, and net flow.

A power/output cable allows outputs for use with a variety of Seametrics and other displays and controls for remote reading and telemetry applications. Pulse output is standard on all models. In addition, 4-20mA passive current loop, HART protocol, high speed digital, and Modbus® protocol outputs are optional on the externally powered units, depending on model.

Features

Rate and total indicator with light sensor
button controls

Power and Output cable
port access

Equalization lug

Santoprene/Polypropylene Liner

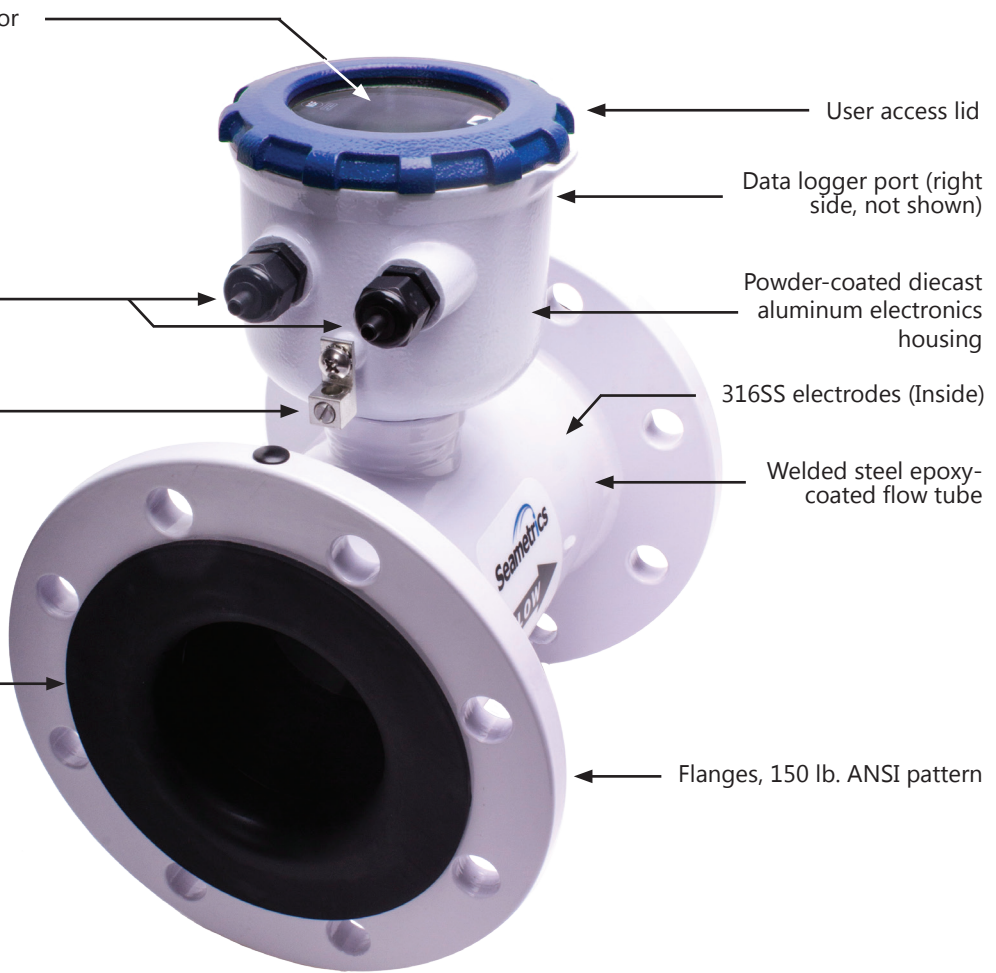

User access lid

Data logger port (right side, not shown)

Powder-coated diecast aluminum electronics housing

316SS electrodes (Inside)

Welded steel epoxy-coated flow tube

Flanges, 150 lb. ANSI pattern

iMAG 4700

No moving parts!

Specifications*

Pipe Sizes	4", 6", 8", 10", 12" (For 3" version, see iMAG 4600-300.)			
Flanges	150 lb. ANSI Pattern			
Pressure	150 psi (10.3 bar) line pressure			
Temperature	Operating	10° to 130° F (-12° to 54° C)		
	Storage	-40° to 158° F (-40° to 70° C)		
Accuracy	± 1.0% of reading, ± 0.025% of full-scale flow from low flow cutoff to maximum flow rate of 10 m/sec			
Low Flow Cutoff	0.5% of maximum flow rate			
Material	Body (4"-12")	Welded steel, epoxy-coated		
	Liner (4"-12")	Santoprene flange/Polypropylene liner body		
	Electronics Housing	Powder-coated diecast aluminum		
	Electrodes	316 stainless steel		
Display	Type	128x64 dot-matrix LCD		
	Digits	5 Digit Rate	8 Digit Total	
	Units	Rate Volume Units	Rate Time Units	Total Volume Units
		<i>Please Note: All iMAG meters are factory set for gallons per minute (GPM) rate and gallons total. If other units are required, they can be set in the field.</i>		Gallons Cubic Meters x 1000 Gallons x 1000 Cubic Feet Million Gallons Cubic Feet x 1000 Liters Million Cubic Feet Kilo Liters Imperial Gallons Mega Liters Imperial Gallons x 1000 Barrels (42 gallons) Million Imperial Gallons Cubic Meters
	Bidirectional¹	Forward Total, Reverse Total, Net Total		
Power	DC Power	9-36 Vdc @ 250 mA max, 30 mA average, with two lithium 3.6V 'D' batteries, replaceable.		
	Battery	Two lithium 3.6V 'D' batteries, replaceable.		
Scaled Pulse Output	Signal	Current sinking pulse, isolated, 36 Vdc at 10 mA max		
	Pulse Rates	User-scalable from 0.1 to 99,999.9 volume units/pulse. Pulse width is one-half of pulse period with minimum pulse width of 2.5 ms, 200 pulses/sec max, 150 pulses/sec max with battery option		
Options	4-20mA Current Loop	Isolated, passive, 24Vdc, 650 Ω maximum current loop		
	HART/4-20mA	HART protocol over 4-20mA line		
	High Speed Digital Output	Isolated, open collector, 24 Vdc		
	Serial Communications	Isolated, asynchronous serial RS485 (Reconfigurable for RS232 or 3.3V CMOS), Modbus® RTU protocol (factory selectable)		
Cable	Power/Output Cable	20ft (6m) standard length polyurethane jacketed cable—for power and outputs (lengths up to 200' available).		
Conductivity	>20 microSiemens/cm			
Empty Pipe Detection	Hardware/software, conductivity-based			
Regulatory	CE (EN 61326) pending, NSF-61			
Environmental	IP68 (10ft (3m) depth, continuously)			

Modbus is a registered trademark of Schneider Electric.

* Specifications subject to change. Please consult our website for the most current data (www.seametrics.com).

¹ If forward and reverse flow data needs to be sent to another device, either the Digital or Modbus output is required.

² Rate Time Unit is available in Day only.

Dimensions

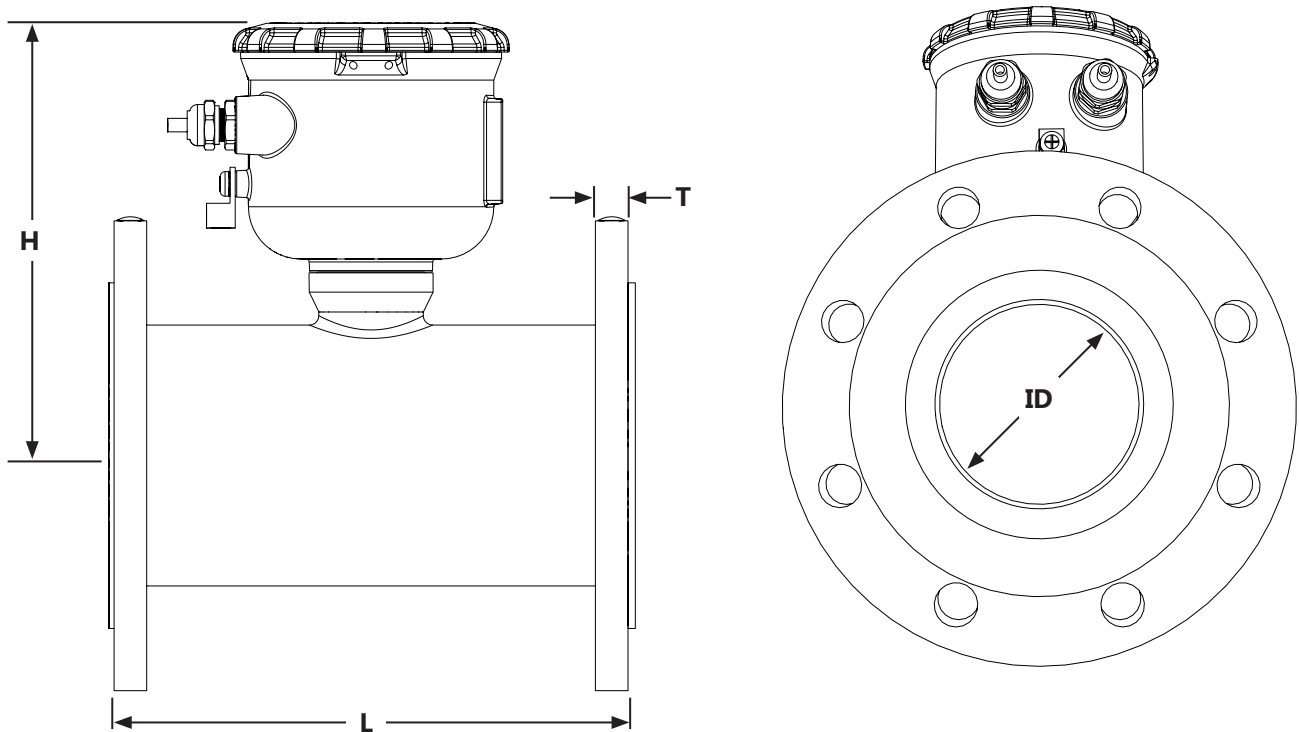

iMAG Meter Size	L		H		T		ID		Shipping Weight		Flange Bolt Torque	
	inch	mm	inch	mm	inch	mm	inch	mm	lbs	Kg	ft-lb	Nm
4"	10.24	260	8.3	211	.62	15.7	3.12	79	25	11.5	20	27
6"	12.27	312	9.1	231	.69	17.5	5.05	128	40	18	42	57
8"	14.24	362	10.1	257	.69	17.5	6.44	164	62	28	65	88
10"	18.18	462	11.2	284	.69	17.5	8.61	219	118	53.5	73	99
12"	19.68	500	12.2	310	.81	20.6	10.55	268	160	72.5	97	132
Flanges	Standard ANSI 150 lb. drilling								Cable 1 lb.		REPEAT CROSS-TIGHTENING PATTERN TO FINAL TORQUE VALUE	

Install security seal during installation if regulations require.



iMAG Accuracy

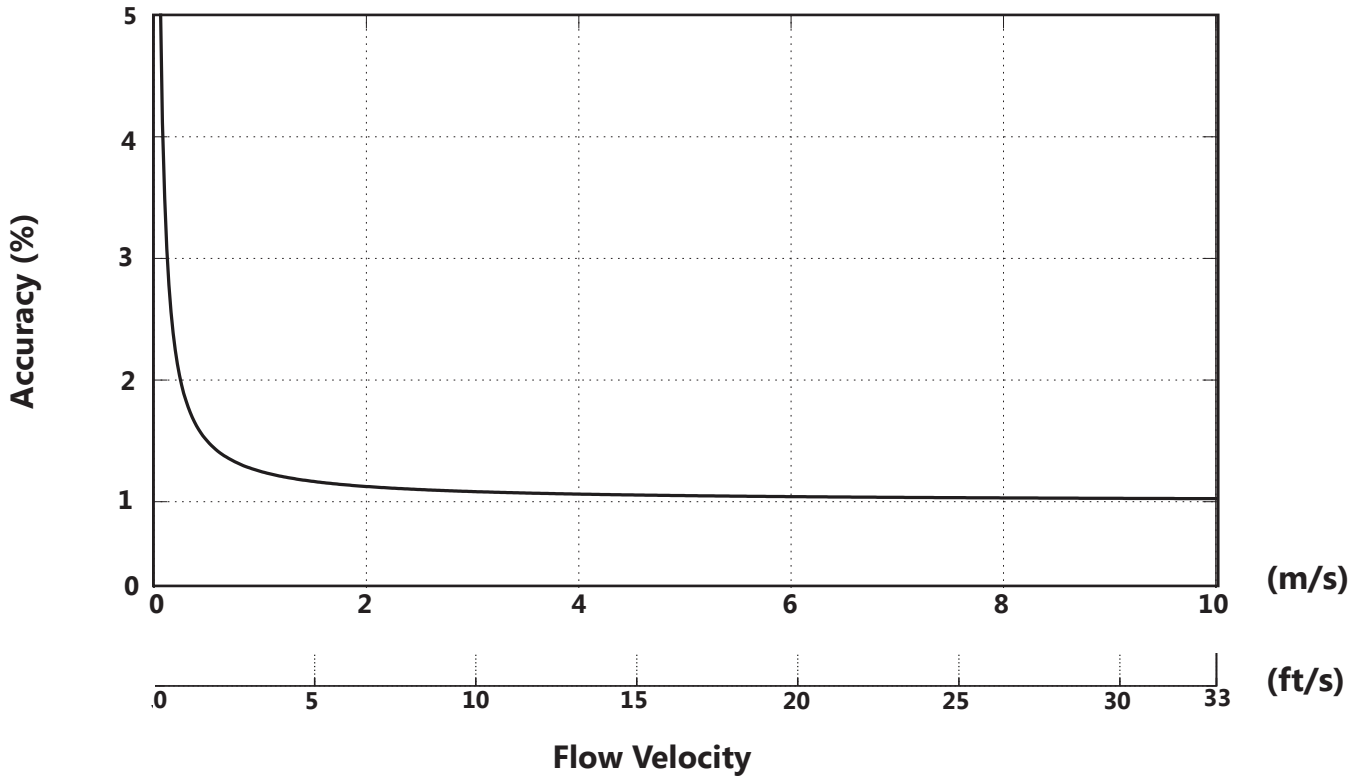

Flow Rate (4" - 12")

Pipe Size <i>(Inches in diameter)</i>	4"	6"	8"	10"	12"
Max Flow Rate <i>(Gallons/Minute)</i>	1285	2891	5140	8031	11565
Cut-off (min) Flow Rate <i>(Gallons/Minute)</i>	6.43	14.46	25.70	40.15	57.82
Max Flow Rate <i>(Liters/Second)</i>	81	182	324	507	730
Cut-off (min) Flow Rate <i>(Liters/Second)</i>	0.41	0.91	1.62	2.54	3.65
Max Flow Velocity <i>(Meters/Second)</i>	10	10	10	10	10

Positioning the Meter



CAUTION: These flow sensors are not recommended where installation may expose the flow sensor to boiler pressure and temperature. Maximum recommended operating temperature is 130° F.

These meters can be installed horizontally, vertically (with downward flow), or in any radial position. **Using a check valve on the upstream side of the meter, and/or an air vent (vacuum relief valve) in the same, unobstructed run of pipe as the meter, is required in any installation where the meter may be exposed to suction when the system is not in normal operation. Suction can cause damage to the liner. Liner damage caused by suction, without the use of a check valve and/or air vent, may void the warranty.**

Straight Pipe Recommendations. The iMAG requires straight pipe before and after the meter for best accuracy. However, the ability of electromagnetic meters to average the flow across the entire pipe allows for shorter straight pipe recommendations than most mechanical meters (see page 8).

Full Pipe Recommendations. To prevent false readings, this meter is designed to indicate 'EMPTY PIPE' if one or more electrodes is exposed. For highest accuracy, install the meter so that the pipe will be full when there is flow. If air bubbles may be present in the pipe or sludge accumulation is an issue, rotate the meter by one flange hole to position the control housing at a 45° angle (see diagrams on page 9).

Fittings. The iMAG has ANSI 150 lb. drilled flanges and will mate with any other ANSI 150 lb. flanges. See table on page 5 for flange bolt tightening torque specifications.

Calibration. The iMAG is factory-calibrated and will not require any form of field calibration.

Chemical Injection. When the iMAG is used in a chemical injection application, the chemical injection point must be placed downstream of the magmeter OR far enough upstream for complete mixing to occur before the fluid reaches the meter. When unmixed chemical alternates with water passing through the meter, the rapid changes in conductivity may cause sudden spikes and drops in the meter's reading, resulting in inaccurate measurement. The magmeter will re-stabilize, however, with a steady flow of fluid of uniform conductivity.



CAUTION: In chemical injection applications, install chemical injection point downstream of magmeter, or far enough upstream to allow complete mixing of fluids.

Equalization and Grounding

Metal Pipe Installations. To equalize the electrical potential of the fluid, the iMAG meter, and the surrounding pipe, secure the flange plates (factory-installed on the equalization wire) to both pipe flanges at one of the bolt holes, as shown below. Be sure the lock washer fits between the pipe flange and the flange plate. For the best electrical bonding, remove rust and paint to expose clean, bare metal where the equalization flange plate lock washer contacts the pipe flange. Connection must be inspected periodically for corrosion to maintain the necessary low resistance connection.

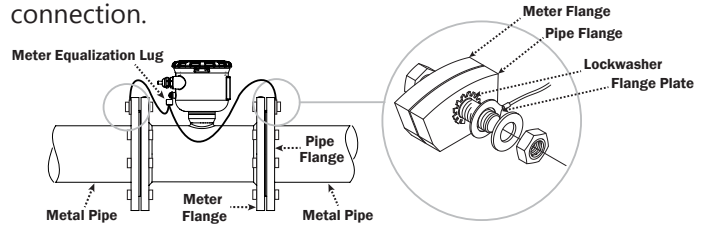

Run wire from equalization lug to both pipe flanges; secure flange plates under bolt heads as shown.



CAUTION: Grounding rings are recommended for installations that could damage the flange gasket.

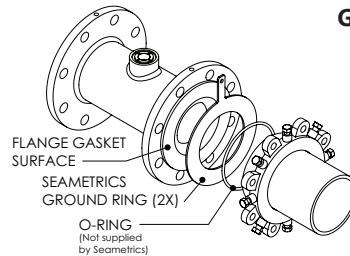

Grounding Ring Part Numbers

- 4" = 100876
- 6" = 100877
- 8" = 100878
- 10" = 100879
- 12" = 103288

Plastic Pipe Installations. When the iMAG is installed in a plastic piping system, grounding rings may be required, especially in the presence of electrical interference sources such as VFD pump drives. As shown in the diagram below, the equalization wires should then be connected to the grounding ring tabs instead of the flange bolts as in metal piping installations. Where lightning is a threat, or in severe electrical environments, an optional connection to a nearby equipment ground or ground rod may be advisable.

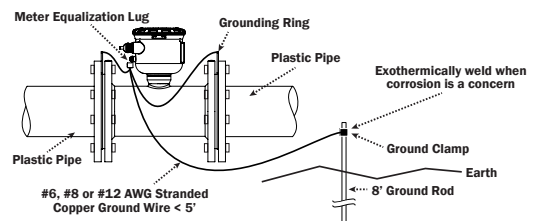

Straight Pipe Recommendations (X = diameter)

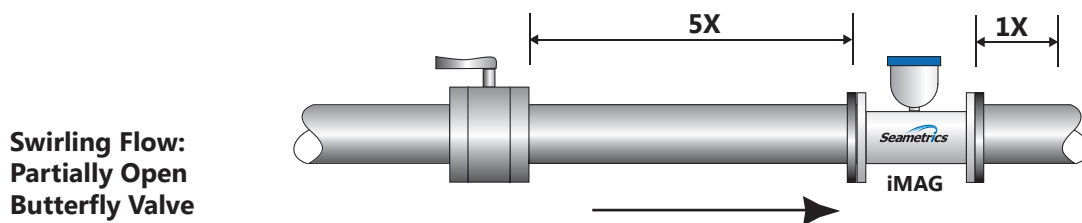
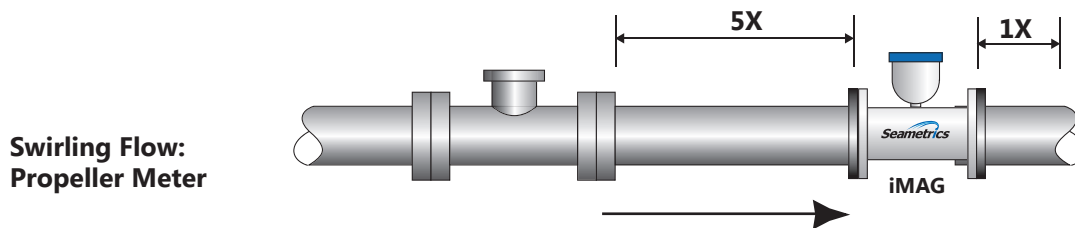
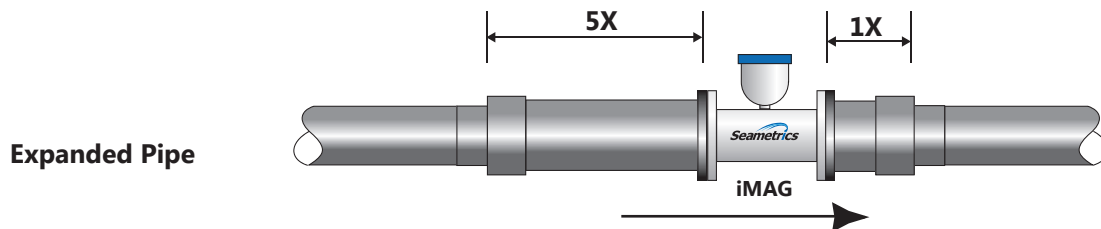
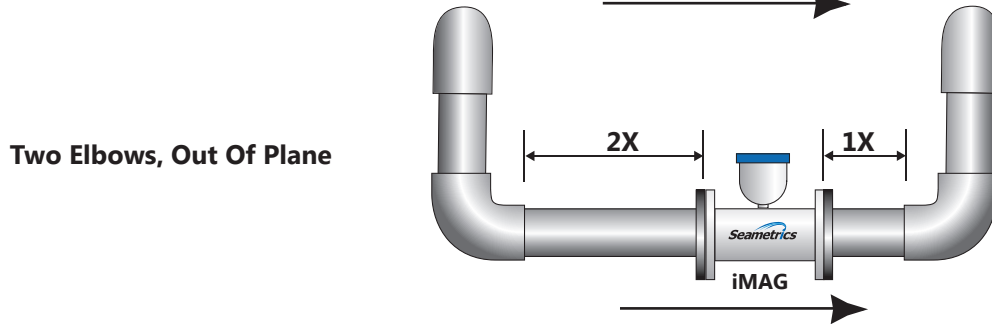
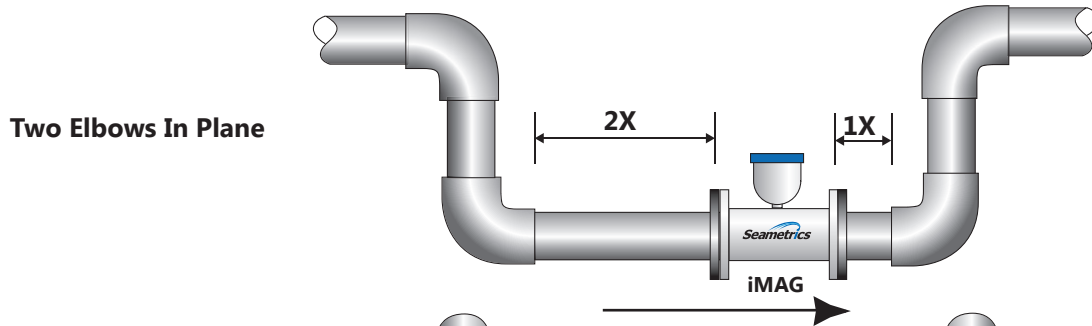
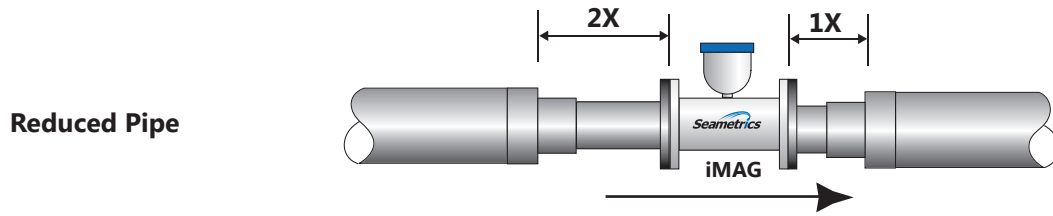

Full Pipe Recommendations

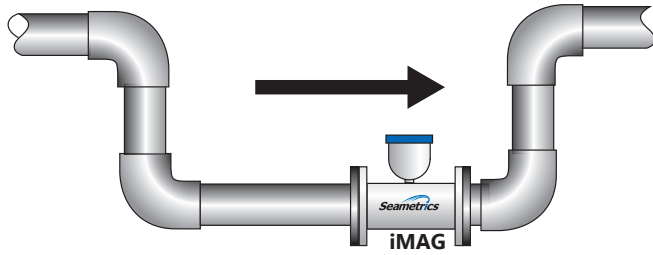

Recommended:
Keep pipe full at meter for accuracy

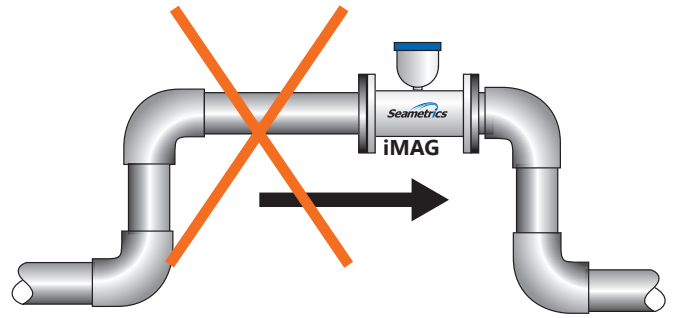

Not Ideal:
Allows air pockets to form at meter

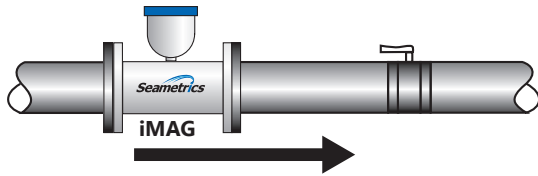

Recommended:
Keeps pipe full at meter for accuracy

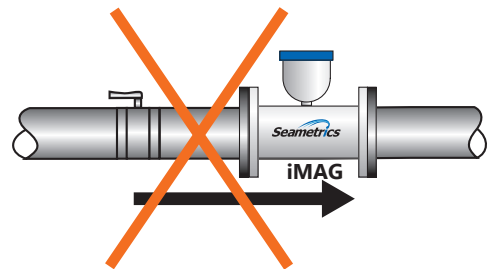

Not Ideal:
Post-valve cavitation can create air pocket

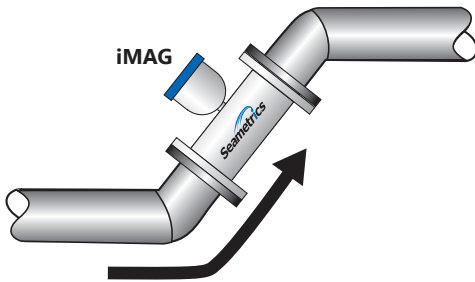

Recommended:
Allows air to bleed off

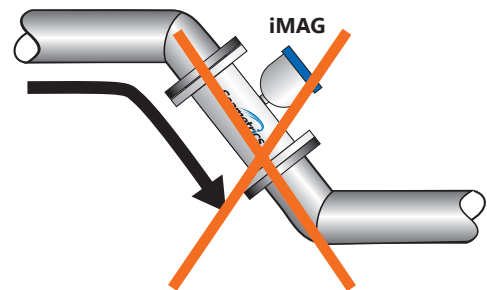

Not Ideal:
Air can be trapped

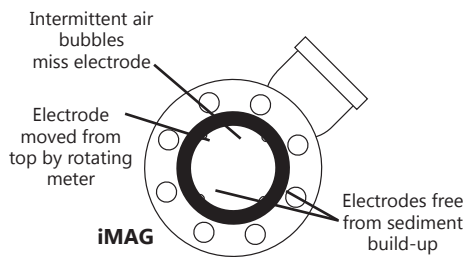

Recommended:
Improved accuracy results from unimpeded electrodes

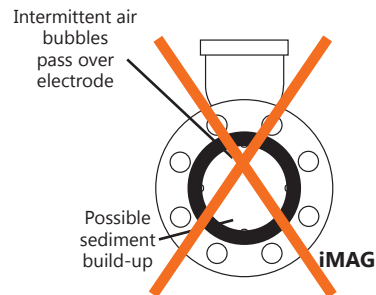

Not Ideal:
Air bubbles and sediment on the electrodes can affect accuracy

General Cable Information

In the iMAG 4700 meter, there are a maximum of two Power/Output cables that can be installed. These cables contain the wires for DC power and for any output (scaled pulse, 4-20mA, Modbus®, HART, and high speed digital). (See Sample Cable Wiring Diagrams and Cable Wiring Table.) It is up to the user to decide how to best organize the wiring for the application.

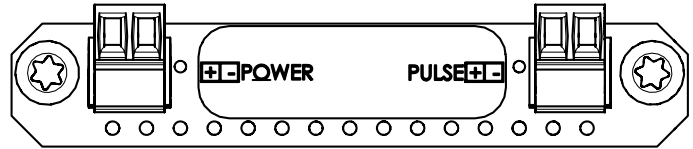

Two 2-pin Connectors for iMAG 4700 Battery Version

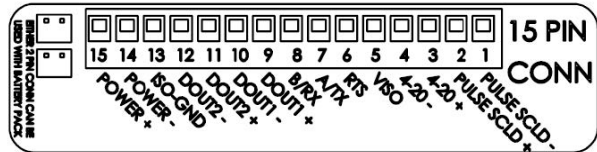
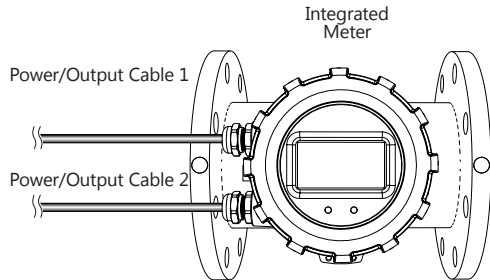

15 Pin Connector for iMAG 4700 DC Versions

The iMAG 4700 is available in either Battery or external DC versions.

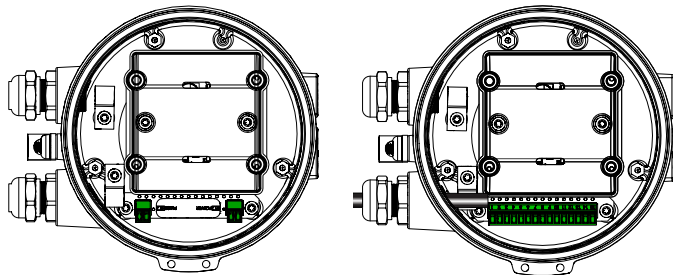

Battery version with two 2-pin connectors

DC version with a 15-pin connector

Cable Gland Opening and Sealing



WARNING: Improper sealing of glands or cables will invalidate any warranty.

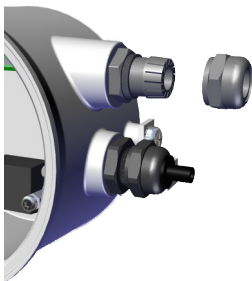

Loosen cable gland sealing nut and remove plug before inserting cable.

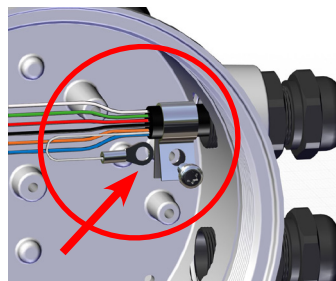

Clamp cable with strain relief clips. Attach drain wire lug to bracket post.

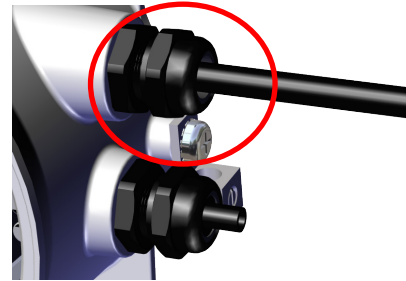

CRITICAL!
Torque cable gland sealing nut to 22 in-lbs.

Cable Installation

4700 Wiring - Battery Only Version - no external pulse output

On the battery only version, if you are going to only use the integrated display, no output wiring is needed. If you want to wire in the scaled pulse option, follow the instructions to the right.

1. Unscrew the display lid and remove it.
2. Remove the 3 screws holding the display assembly and remove it from the meter exposing the internal connectors. Be sure to **NOT** undo any connections to the display assembly as you remove it.
3. **Plug the battery cable into the circuit board, as shown below.**

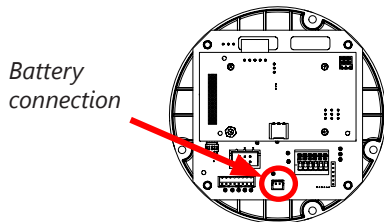

4700 Wiring - DC Version or Battery Only Version with external pulse output.

1. Unscrew the display lid and remove it.
2. Remove the 3 screws holding the display assembly and remove it from the meter exposing the internal connectors. Be sure to **NOT** undo any connections to the display assembly as you remove it.
3. The DC version comes with a 15 pin screw connector. Remove this from its bag. (On the battery version, there are two 2-pin connectors already installed.)
4. Loosen the cable gland sealing nut(s), removing the plug(s) and insert the cable end(s) through the open hole(s).
5. Strip cable jacket and conductors and install the wires into the connectors in their respective locations for your options, Modbus®, pulse, HART, etc. (See Cable Wiring Table for details.)
6. If using the 15 pin screw connector, plug it into its socket.
7. **Plug the battery cable into the circuit board, as shown to the left.**
8. Secure the cables inside the internal strain relief clip and tighten the cable gland sealing nut securely. (torque nut to 22 in-lbs.). A loose nut could cause moisture ingress and compromise the meter head's IP68 rating, voiding the warranty.
9. Remount the display assembly, being careful to not pinch any wires, and install the display assembly screws.
10. Reinstall the display lid, being sure to avoid cross-threading the lid.

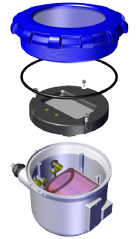

Wiring Diagrams

Unscrew the display lid and remove it. Remove the 3 screws holding the display assembly and remove it from the meter. Remove the 15 pin screw connector from its bag. Install the wires through the cable glands into the 15 pin screw connector in their respective locations. Plug the 15 pin screw connector into its socket. (C1 = power/output cable, C2 = power/output cable 2)

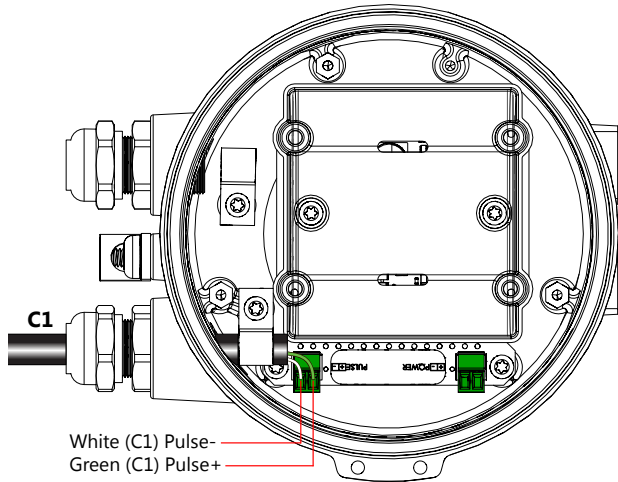

Battery Power with Pulse (BXX)

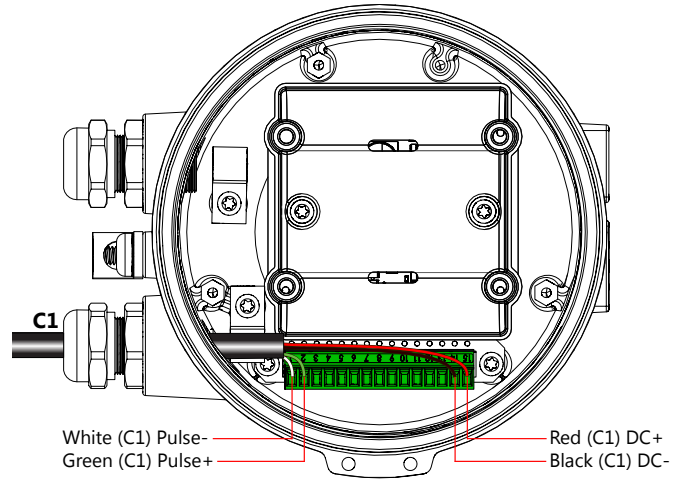

DC Power with Pulse (D1X/D2X)

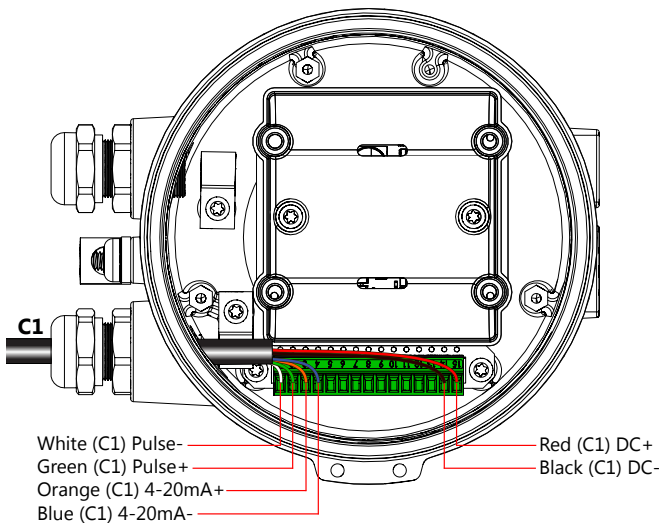

DC Power with Pulse and 4-20mA (D1L/D2L)

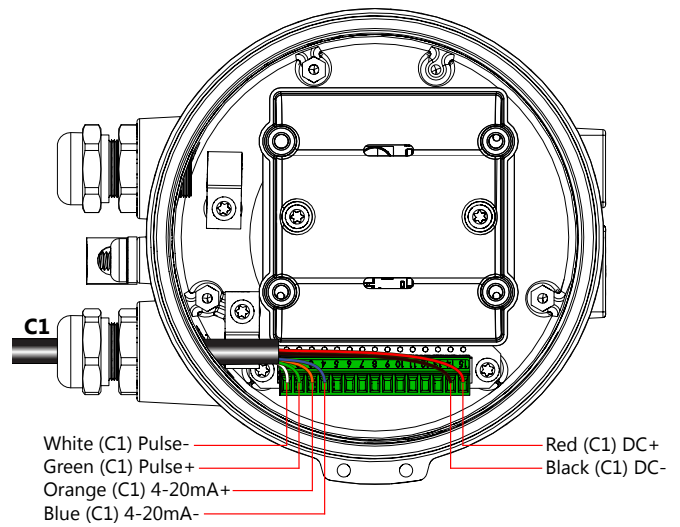

DC Power with Pulse and HART/4-20mA (D1H/D2H)

Wiring Diagrams (continued)

Unscrew the display lid and remove it. Remove the 3 screws holding the display assembly and remove it from the meter. Remove the 15 pin screw connector from its bag. Install the wires through the cable glands into the 15 pin screw connector in their respective locations. Plug the 15 pin screw connector into its socket. (C1 = power/output cable, C2 = power/output cable 2)

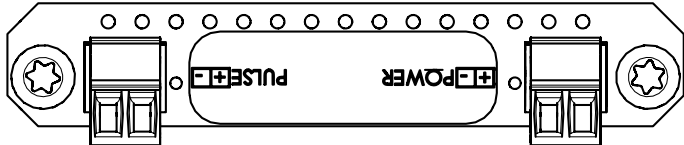
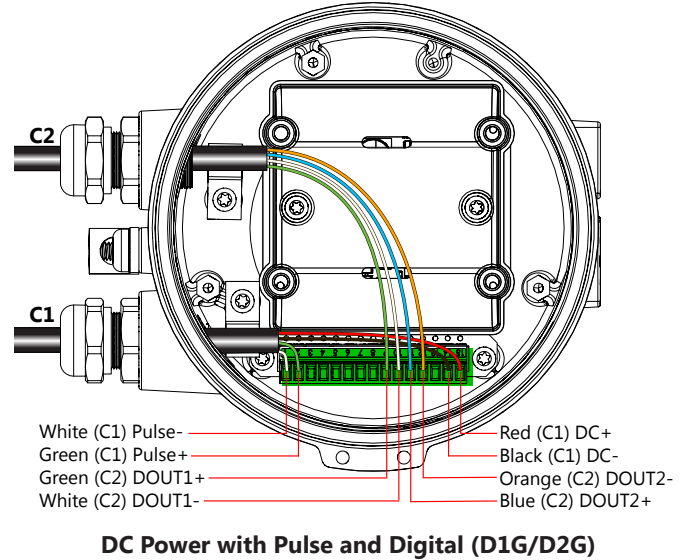
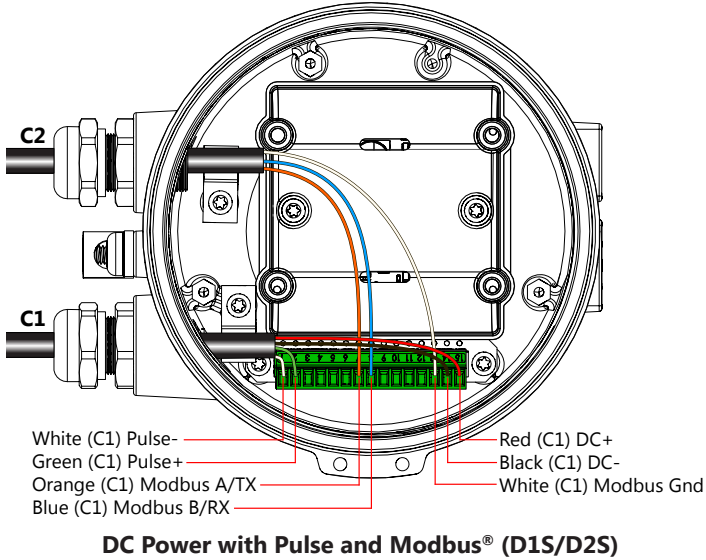

Two 2-pin Connectors for iMAG 4700 Battery Version

Note that when viewing the connectors from the front of the meter, the labels will be upside down, as shown here, with numbering going from left to right.

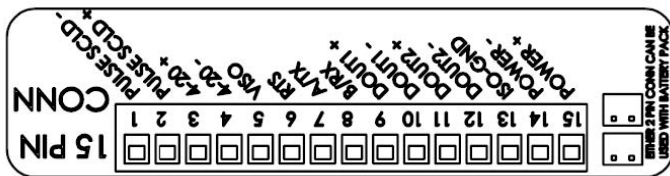

15 Pin Connector for iMAG 4700 DC Versions

Plug the backup battery cable into the circuit board

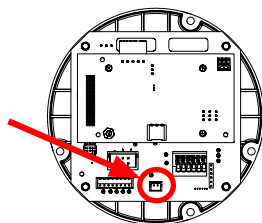

Cable Wiring Table

PIN	15	14	13	12	11	10	9	8	7	6	5	4	3	2	1
O ID	PWR+	PWR-	ISO-GND	DOUT 2-	DOUT 2+	DOUT 1-	DOUT 1+	B/RX	A/TX	RTS	VISO	4-20 -	4-20 +	PULSE SCLD+	PULSE SCLD-
BXX														GREEN C1	WHITE C1
D1X/D2X	RED C1	BLACK C1												GREEN C1	WHITE C1
D1L/D2L	RED C1	BLACK C1										BLUE C1	ORNG C1	GREEN C1	WHITE C1
D1H/D2H	RED C1	BLACK C1										BLUE C1	ORNG C1	GREEN C1	WHITE C1
D1S/D2S	RED C1	BLACK C1	WHITE C2					BLUE C2	ORNG C2					GREEN C1	WHITE C1
D1G/D2G	RED C1	BLACK C1		ORNG C2	BLUE C2	WHITE C2	GREEN C2							GREEN C1	WHITE C1

(C1 = power/output cable 1 C2 = power/output cable 2)

Option IDs

- O ID** **POWER SOURCE / OUTPUT(S)**
BXX = BATTERY POWER / PULSE SCALED
D1X/D2X = DC POWER / PULSE SCALED
D1L/D2L = DC POWER / PULSE SCALED AND 4-20mA
D1H/D2H = DC POWER / PULSE SCALED AND HART/4-20mA
D1S/D2S = DC POWER / PULSE SCALED AND MODBUS®

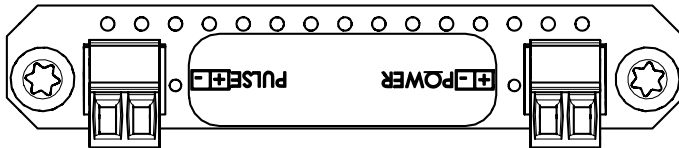

Two 2-pin Connectors for iMAG 4700 Battery Version

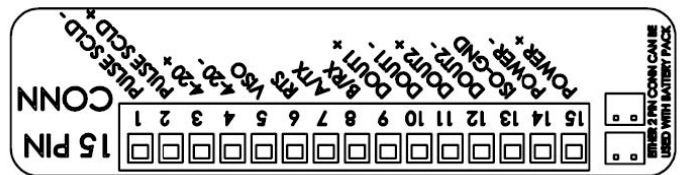

15 Pin Connector for iMAG 4700 DC Versions

Note that when viewing the connectors from the front of the meter, the labels will be upside down, as shown above, with numbering going from left to right.

Pulse or Digital Output Application - Sourcing Mode (Recommended for $R_{in} < 30k\Omega$)

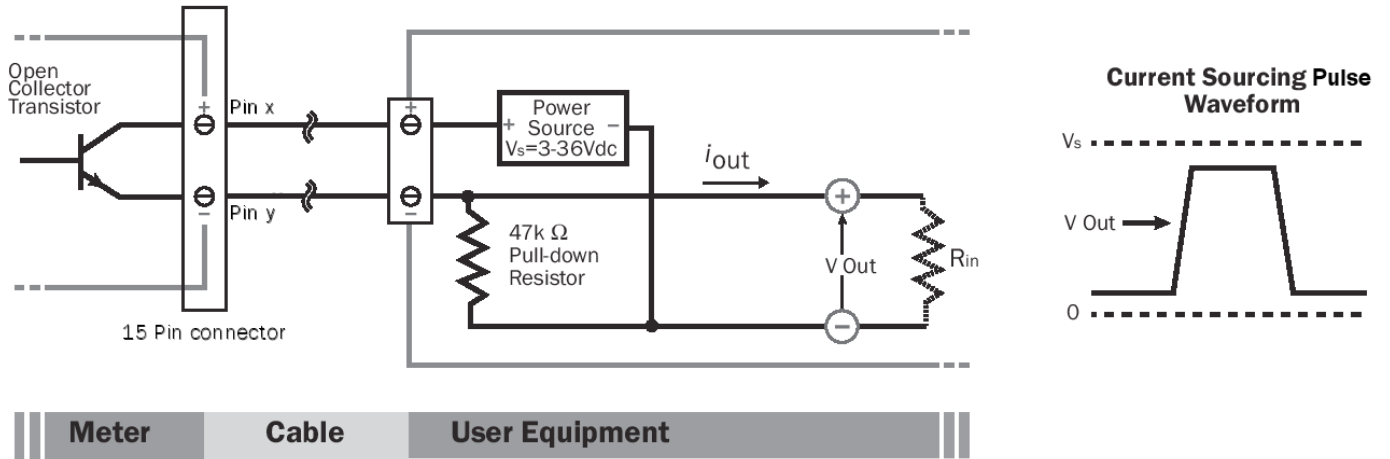

Pulse or Digital Output Application - Sinking Mode (Recommended for $R_{in} > 30k\Omega$)

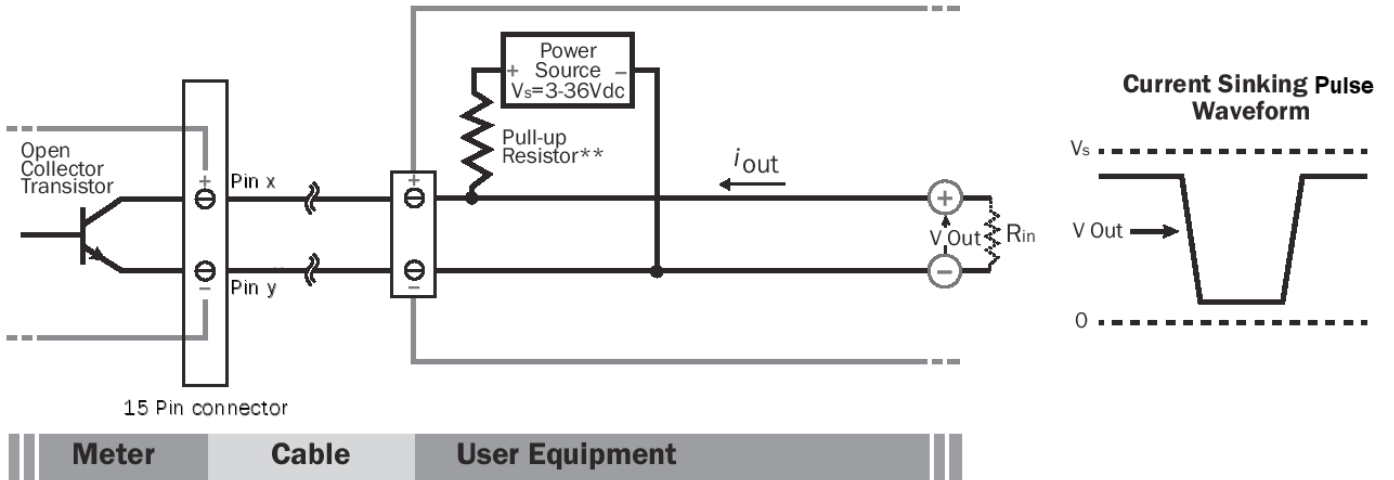

Analog (4-20mA Current Loop) Output Application

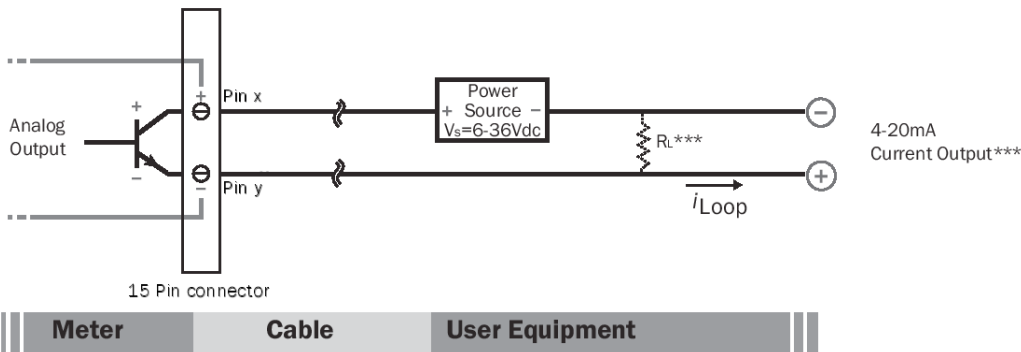

** Minimum resistor value is $(100 \times V_s)$ ohms. Higher resistances maybe used depending on frequency and cable length. Longer cables and high frequencies require lower resistance.

*** Resistor R_L converts 4-20mA current to voltage for voltage input only devices.

Cable Shield. In general, the cable shield and its bare drain wire should be left unconnected at the user equipment end of the cable to minimize “ground loop” problems.

Pulse Output Configuration. A pulse output is standard on all models. Since this is an isolated output, the external equipment must include a DC power source to regenerate the pulse from the open-collector output (transistor equivalent of a contact closure). A pull-up or pull-down resistor may be needed if not included in the user equipment as shown in the diagrams. Both the power source and resistor may be supplied internally in some types of control and monitoring devices. If not, as for most PLC discrete input modules, they must be added externally at the module input terminals. The pulse output rate in volume units/pulse can be set by the user via the SET P tab on the meter’s setup menus.

Analog Output (4-20mA) Configuration. *(Not available on battery only units.)* Since the meter’s analog output is isolated and passive, loop power must be supplied externally as shown on previous page. (In addition, an external resistor R_L will be needed to convert the loop current to voltage for voltage-only input devices.) The meter’s loop transmitter minimum voltage drop is 6Vdc (8Vdc with HART) which, with wiring resistance and loop power supply voltage, will determine the maximum resistance for R_L . The flow rates corresponding to 4 and 20mA can be set by the user via the SET 4 and SET20 tabs on the meter’s setup menus.

HART Configuration. *(Not available on battery only units.)* The HART protocol, rev.7.5, allows for a Polling address between 0 and 63. The default value in the iMAG is 0. To change the Polling address, use iMAG menu HPOLL to set the Polling address.

To get to this menu, move to the EXIT tab and tap the left button 4 times. This will bring up the SUBMENU page. Navigate to the HPOLL tab. Use the left button to select the Polling address.

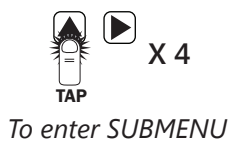

(See Changing Flow Meter Settings later in these instructions for details in using the menu system.)

A minimum of 250 ohms of loop resistance must be present in order for the HART modem to correctly and reliably demodulate FSK voltage. With this in mind, the maximum loop resistance* for the iMAG HART interface cannot be exceeded in order to assure correct operation.

The iMAG HART interface is HART compatible. All the commands have been implemented in accordance with the HART Protocol Specification published by HART Foundation. A HART Communicator can be used with the iMAG, even in the absence of DD files, by taking advantage of the Generic Online Menu capability of a Communicator. This means that a generic menu is automatically available when DD files are not present.

The following information from the iMAG HART can be displayed on the Communicator using the generic menu:

PV	Flowrate in units selected for iMAG
PV Loop Current	Loop current in mA
PV LRV	Lower range value of PV in units selected for iMAG
PV URV	Upper range of PV in units selected for iMAG

**4-20 mA loop has maximum loop resistance of 650ohms and requires a 24Vdc power supply.*

Modbus® Serial Communication Configuration (factory configured). *(Not available on battery only units.)* These connections provide a half-duplex, isolated, RS485 serial communications port using the Modbus messaging protocol. The port is reconfigurable by internal jumper settings to full-duplex RS232 or 3.3V CMOS. The TXD connection is the transmitted data output from the meter and RXD is the received data input to the meter. See Seametric’s Modbus Interface Description, LT-103393 (available at www.seametrics.com) for supported Modbus message protocol and electrical interface specifications.

Digital Output Configuration. *(Not available on battery only units.)* These outputs are electrically similar to the Pulse Output described above except they are capable of output frequencies up to 10kHz. The frequency output scaling can be set by the user via the FOUT tab on the meter’s setup menus. Selections are: 500Hz and 1, 2, 5 and 10 KHz at maximum flow rate.

K-Factors for High Speed Digital Output (High Frequency)

Size	FOUT (Hz)				
	500	1K	2K	5K	10K
4"	23.35	46.69	93.39	233.5	466.9
6"	10.38	20.75	41.51	103.8	207.5
8"	5.837	11.67	23.35	58.37	116.7
10"	3.736	7.471	14.94	37.36	74.71
12"	2.594	5.188	10.38	25.94	51.88

Changing Flow Meter Settings

Home Screen and General Navigation

The HOME Screen displays TOTAL FORWARD flow volume, direction of the flow total and flow RATE along with status conditions such as Empty Pipe. Two buttons below the LCD display are used to access menu screens for viewing and changing meter setup parameters.



These two buttons are light sensors which can detect when a finger is covering them. Only three button touch actions are needed to control navigation through the menus, settings changes and back to the home screen.

HORIZONTAL SCROLLING:

Tap right button to scroll horizontally through menu tabs or move horizontally within a tab dialog when applicable.



SELECT:

Tap left button to change a highlighted item within a tab dialog.



ENTER/EXIT:

Hold left button while tapping right button once to enter or exit a tab dialog or to navigate between the HOME and other menu screens.



To enter the Menu System perform the hold and tap sequence. All menu screens consist of two rows of tabs surrounding a dialog box that lets you view and change setup parameters.

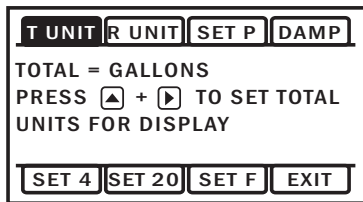

Once in the Menu System, move from tab to tab by tapping the right button. (See the next page for details on the various available tabs.)



Making Selections

Select the parameter. In the screen for the highlighted tab you will see the current parameter value for that tab. Tapping the right button, move to the tab for the parameter you want to change.



In this example, the first line indicates that the current unit for the TOTAL is GALLONS. The next two lines tell you what to do next.

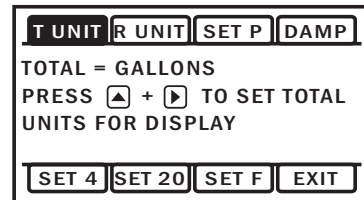

If you would like to change the TOTAL units, just perform the hold and tap sequence to bring up a screen to change the setting.

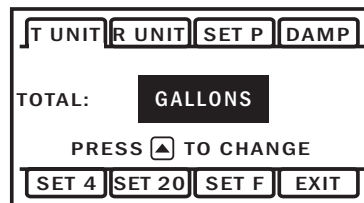

Select a new setting. Select the new setting by scrolling through a list of selections as in the screen illustration below by tapping the left button to find a different TOTAL unit.



Accept changes. To accept any changes you have made, perform the hold and tap sequence.



When finished making changes. When you are finished making changes, move to the EXIT tab using the right button.



To return to the HOME screen, perform the hold and tap sequence.



Standard Menu Options

Note: Available options will depend on specific meter configuration. Not all options are available on all meters. **Options not ordered with your meter will not appear on the meter menu.**

T UNIT

View or change TOTAL volume units

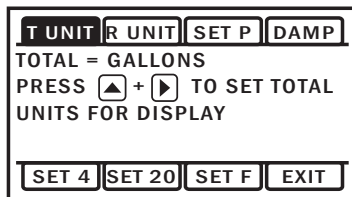

SET 4

View or change flow rate corresponding to 4mA. *(Externally powered units only)*

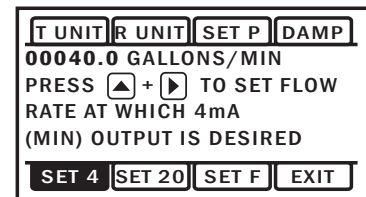

R UNIT

View or change flow RATE units

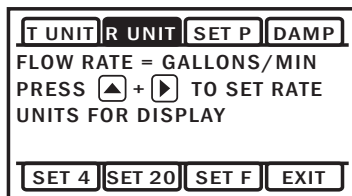

SET 20

View or change flow rate corresponding to 20mA. *(Externally powered units only)*

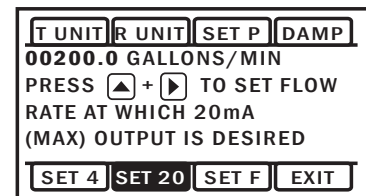

SET P

View or change pulse output scaling

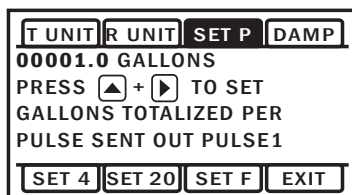

SET F

View or change high frequency output scaling. *(Externally powered units only)*

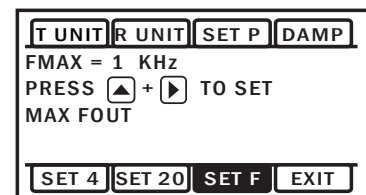

DAMP

View or change filter settings

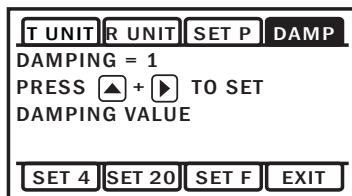

EXIT

Return to HOME SCREEN or enter SUBMENU

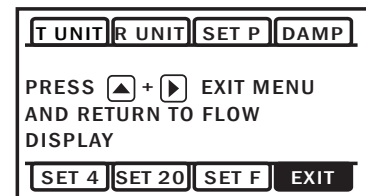

Special SUBMENU for further options

The EXIT tab in the MAIN MENU has a second function. If, instead of using the hold and tap sequence to return to the HOME screen, you tap four times, you will be redirected to a SUBMENU screen from which you can access several more options.

Navigation in this SUBMENU is the same as for the MAIN MENU. Whenever you wish, go to the EXIT tab in the SUBMENU and perform the hold and tap sequence to return to the MAIN MENU.

- INFO: Meter model number, serial number, and firmware version.
- COMM: Modbus® baud rate and parity. *(Not available on battery only units.)*
- MBID: Modbus® address *(Not available on battery only units.)*
- FL DIR: Bidirectional flow display options: FWD, REV, or NET.
- SAMP: Sample rate *(Battery powered version only.)*
- HPOLL: HART Address *(Not available on battery only units.)*
- EXIT: Return to MAIN MENU.

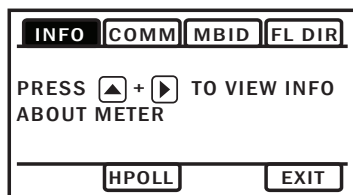

Sub-Menu

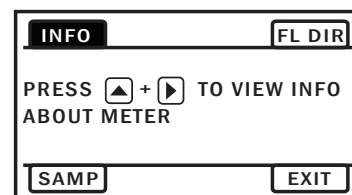

Sub-Menu - Battery Only Version

Battery Powered Units

The iMAG 4700 meter can come configured with two replaceable 3.6V lithium 'D' batteries. In this configuration, the only option/output is the scaled pulse output which comes standard. The scaled output for the battery powered option has a maximum pulse rate of 150 pulses/second, with a fixed pulse width of 2.5ms. Be sure to set your P value such that the meter will function properly over the flow range in your application. The sample rate of the meter is user selectable through the SAMP tab in the meter's sub-menu. Sample periods of 1/5, 1/3, 1, 3, 5, 15, 30, and 60 seconds can be selected. Larger sample periods will yield longer battery life but slower response time. Care must be taken to select a sample period that is suitable for your application. See the table below for the expected battery life as a function of sample period.

Battery Life/Sample Period

Sensor sample period(s) (Seconds)	Expected battery life*
1/5 (0.2)	1 year
1/3 (0.33)	1.5 years
1	2.5 years
3	4 years
5	5 years
15	5.5 years
30	6 years
60	6.5 years

**Based on 75% battery capacity at room temperature with no option cards installed.*

NOTE: If a large percentage of the meter's life will be spent below 0.5 meters/second and above cutoff, battery life will be reduced.

Problem	Probable Causes	Things to try...
Blank Display	Faulty wiring from power source to meter	Check for incorrect wiring. Measure voltage with DMM where red and black wires connect to terminal block TB2 inside meter display head. Verify correct polarity and confirm that voltage is steady and between 9Vdc and 32Vdc
	Battery has not been plugged in	Plug in the battery
	Dead battery	Replace battery
Flow rate reading fluctuates excessively when flow is unchanging	Excessively turbulent or unsteady flow due to partially closed valves or other flow obstructions	Eliminate or minimize causes of flow disturbances or increase meter damping
	Pipe not full	Provide back pressure or other means to ensure pipe is filled
	Pulsing flow due to combining multiple upstream flow sources	Move connection point further upstream
	Insufficient mixing of upstream chemicals	Move chemical injection downstream from meter
	Low fluid conductivity < 20 $\mu\text{S}/\text{cm}$	Replace with different type of meter
	Noisy electrical environment	Improve grounding at meter and nearby potentially noisy electrical equipment. Increase distance between meter and electrical noise sources.
Flow Rate appears correct but pulse/ frequency output is low, erratic or absent	Defective or noisy ac switching power supply	Replace power supply
	Wiring incorrect	Compare wiring with appropriate wiring recommendations
	External device input impedance too low	Use sourcing rather than sinking interface connection
Flow Rate appears correct but pulse/frequency output is erratic and/or too high	Cable too long	Reduce interface pull-up resistance
	Electrical noise sources interfering with pulse frequency signal	Isolate, remove or reduce noise sources. Move meter control cable away from noise sources.
	Wrong type of cable	Use only twisted pair cable and ensure both signal wires are on same twisted pair
	Grounding problem	Improve or try different grounding method.

